

**These are general guidelines only and more information may be required on a case by case basis**

A building permit is required for the installation of any **wood burning appliance** including a masonry fireplace, factory built fireplace, certified woodstove, uncertified wood stove and/or a chimney that vents solid fuel burning appliance.

## Required Documents for Building Permit Application

- Fully completed application form
- Floor plan of the room in which the woodstove is to be installed
- Owner Authorization form, if the applicant is not the registered property owner
- **\*\*2 sets** of construction drawings produced to a recognizable standard scale, of which **1 set** of drawings is required to be an **electronic copy** of drawings (PDF only)
- Copy of the manufacturer installation instructions for all ULC/CSA/WH listed appliances

\*\* If hand drawn, plans cannot be submitted on paper greater than 11"x17"

## Floor Plan Requirements

The floor plan should clearly show:

- The room in which the woodstove is to be installed
- The location of the appliance
- The proposed distances from the appliance to any combustible framing

## Construction Drawings showing:

### a. Plan views

- i. Cross Section showing the entire assembly from top to bottom detailing clearances for the appliance and chimney
- ii. Height of the chimney above the roof
- iii. Detail showing placement of stove and the distance from the appliance to any combustible framing

### b. Details

- i. Copy of the manufacturer installation instructions for all ULC/CSA/WH listed woodstoves, pre-fabricated fireplaces and inserts, factory built chimneys, steel liners and chimney accessories

See attached sample drawings for further details

Please note, wood burning appliances are required to be installed by a WETT (Wood Energy Technology Transfer) certified installer. The WETT inspectors' final report will be required in order to close the building permit.

**Response Time**

Once a **complete** building permit application is submitted, the permit will be reviewed within 10 business days.

**Where to apply for a building permit?**

Bring your complete building permit application to the Guelph-Eramosa Township office located at 8348 Wellington Road 124, Monday – Friday, 8.30am – 4.30pm.

**Cost of building permit**

There cost of a wood stove permit is a flat fee of \$130.00 however please refer to Schedule “A” of By-Law 13/2018 for verification that the building permit fees have not changed. These fees cover all plans review, building permit, and resulting inspections. Note: All fees and charges listed herein are payable upon collection of the Building Permit.

**Questions?**

Contact the Building Department Administrative Assistant any time for assistance:

Jenni Spies

Phone: 519.856.9596 X 114

Email: [jspies@get.on.ca](mailto:jspies@get.on.ca)

**NOTE**

**Solid Fuel Burning Appliances must be inspected prior to use.**

**Homeowners must install and maintain smoke alarms on every storey of their home and outside sleeping areas.**

**Carbon Monoxide (CO) detectors must be installed as required by 9.33.4 of the Ontario Building Code.**

## Installation Requirements

Wood burning appliances in Canada are tested and/or listed with three agencies:

- The Canadian Standards Association (CSA)
- Underwriters Laboratories of Canada (ULC)
- Warnock Hersey Professional Services Ltd (WH)

Any wood burning appliance which has been tested by an agency other than the above-mentioned shall be considered unlisted.

These agencies test wood burning appliances to very rigid and exacting standards with respect to design, fabrication, and safety. The clearances specified in the installation instructions for each appliance have been determined from these rigorous tests.

### Woodstoves

Woodstoves which are ULC certified have been tested to ULC S627 “Standard for Space Heaters for use with Solid Fuels” and CSA B366.1 “Solid Fuel Fired Central Heating Appliances”. Installation must be as per manufacturer instructions and Section 9.33.1.1 and 9.33.1.2 respectively of the Ontario Building Code. Any discrepancies between the actual installation and the manufacturer’s instructions will render the certification void. Any reduction in clearances must be done with the shielding as described in CSA B365-01 “Installation Code for Solid Fuel Burning Appliances and Equipment”.

Woodstoves which have not been tested to ULC S627/CSA B366.1, “Standard for Space Heaters for use with Solid Fuels”, are considered unlisted and must be installed as per CSA B365.01, “Installation Code for Solid Fuel Burning Appliances and Equipment”, and Section 9.33.1.1 & 9.33.1.2 of the Ontario Building Code.

### Fireplaces

Recent studies have shown that fireplaces burn excess inside air that causes back draft in other fuel fired appliances in the house. Because this backdraft can pull unburned gases back into the house (the most dangerous of which is carbon monoxide), the Ontario Building Code has made it a requirement that a supply of outside combustion air be provided to the fireplace. Section 9.22.1.4 of the Ontario Building Code outlines the specifications required.

Factory built fireplaces and chimney must show they are certified to ULC S610 ‘Standard for Factory Built Fireplaces’ and must be installed as per the manufacturer instructions.

Masonry fireplaces must be constructed as per the specifications set out in Section 9.22 of the Ontario Building Code.

For more information on the installation of your wood burning appliance, please refer to Part 9 of the Ontario Building Code or contact a certified dealer in your area.

### Chimneys

Factory built chimneys that are venting wood burning stoves, cooking ranges, central heating furnaces and boilers, whether installed new or are used as existing must be certified to ULC S629. Only factory built chimneys certified to this standard can be used to vent a solid fuel burning appliance.

**Township of Guelph Eramosa**

8348 Wellington Road 124 • Box 700 • Rockwood, ON • N0B 2K0

Phone: (519) 856-9596 • Fax: (519) 856-2240

Masonry built chimneys whether built new or existing that are venting wood burning stoves, cooking ranges, central heating furnaces and boilers must have an approved inspection by a WETT certified technician prior to use when a solid fuel burning appliance is installed.

### Flue Pipes

Single wall flue pipes must be manufactured and installed according to the requirements of CSA B365.01.

Double wall flue pipes must be installed according to the manufacturer specifications.

## Sample Drawings

### EXTERNAL HOUSE TOP FLUE OUTLET

#### Measurements required:

- A- Wall Thickness (mm)
- B- Distance to Wall (mm)
- C- Height of Appliance (mm)
- D- Height of Room (mm)
- E- Height from Ground to Eaves (mm)
- F- Roof Pitch (degrees)
- G- Eaves Overhang (mm)

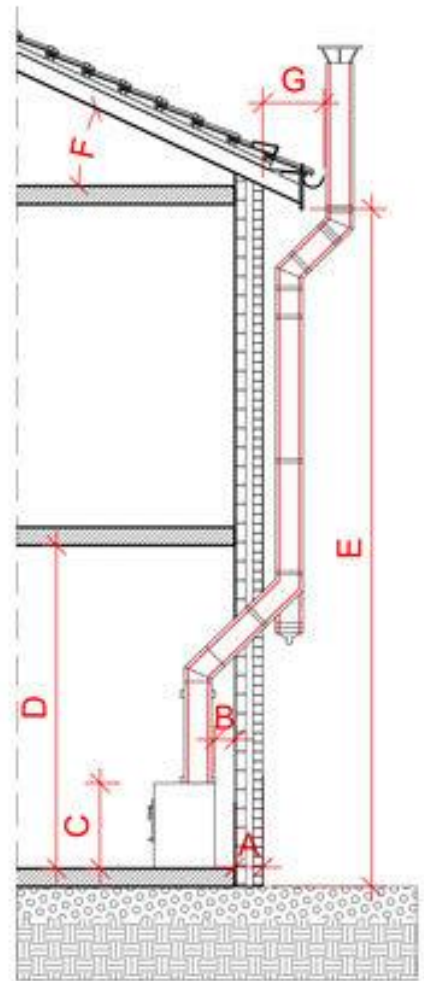

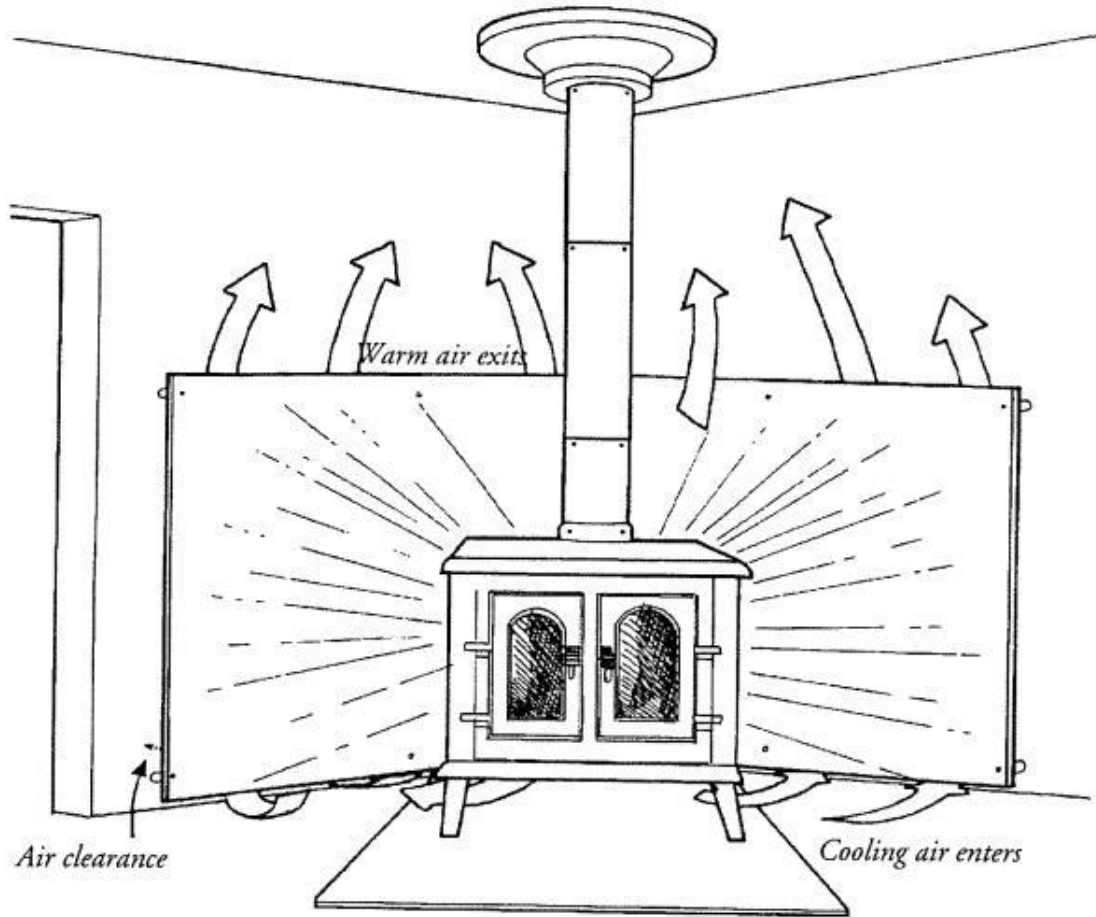

**Reduction in Appliance and Ductwork Clearance from Combustible Material with Specified Forms of Protection**

Type of Protection (shield)	Permitted Reduction in Clearance, %	
	Sides and Rear	Top
Sheet metal, a minimum of 29 gauge in thickness, spaced out at least 21mm (7/8 Inc) by noncombustible spacers	67	50
Ceramic tiles or equivalent noncombustible material or noncombustible supports spaced out at least 21mm (7/8in) by noncombustible spacers	50	33
Ceramic tiles or equivalent noncombustible material or noncombustible supports, with a minimum of 29 gauge sheet metal backing spaced out at least 21mm (7/8in) by noncombustible spacers	67	50
Brick, spaced out at least 21mm (7/8in) by noncombustible spacers	50	N/A
Brick with a minimum of 29 gauge sheet metal backing, spaced out at least 21mm (7/8in) by noncombustible spacers	67	N/A

**Township of Guelph Eramosa**

8348 Wellington Road 124 • Box 700 • Rockwood, ON • N0B 2K0

Phone: (519) 856-9596 • Fax: (519) 856-2240

# Clearance Reduction

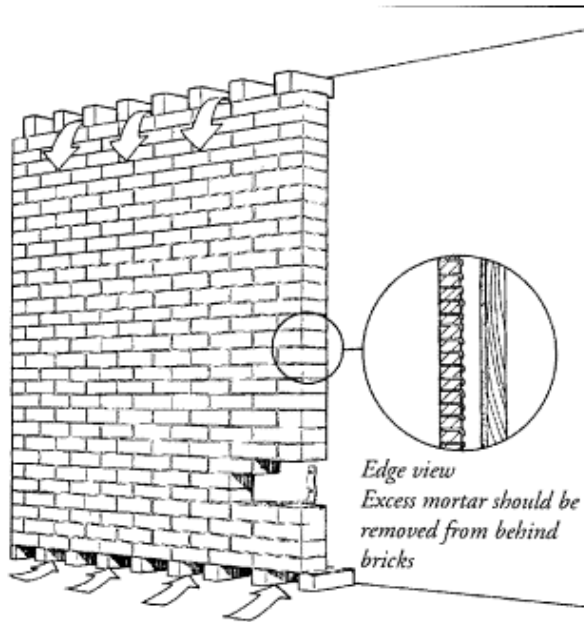

## CONSTRUCTION OF A SOLID BRICK SHIELD

Brick ties spaced on 400 mm (16") centres are needed to support brick shields. They should be anchored firmly into frame studs. The top course of brick can be set on its narrow edge to give the minimum 75 mm (3") edge clearance. This type of shield provides a 50% reduction of clearance.

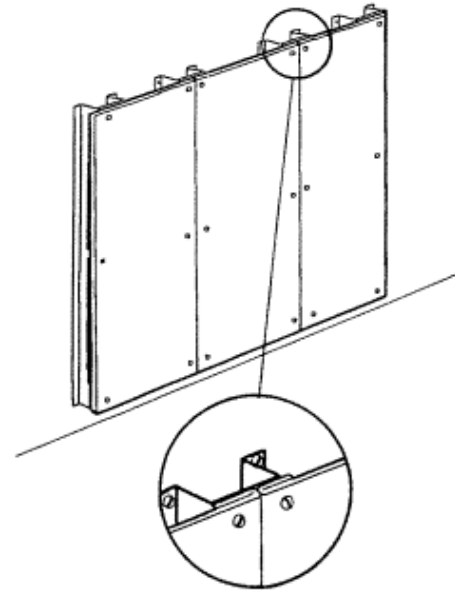

## USING PREFABRICATED METAL SHIELD PANELS

By using channel stand-offs with prefabricated shield panels, you can assemble shields on site quickly. The panels are small enough to be stored easily in the service vehicle and can be assembled to form a shield of the desired width. Precoated roof flashing materials are available in a range of colours.

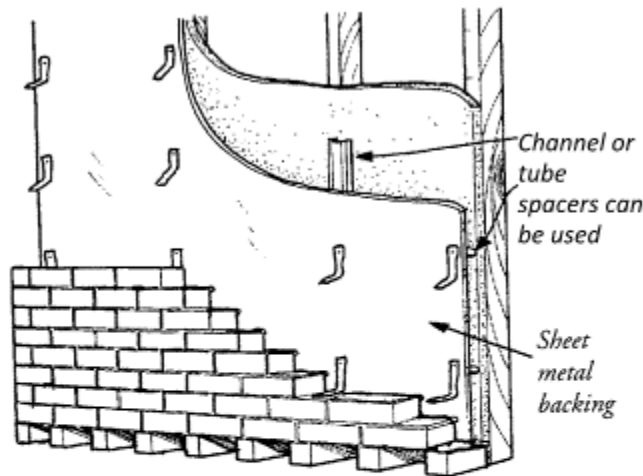

## CONSTRUCTION OF A BRICK SHIELD WITH SHEET METAL BACKING

Steel backing for a brick shield should rest on the bottom course of bricks to ensure airflow behind the shield. If spacer channels rest on the floor or on the bottom course of bricks, be sure to ventilate them at the bottom so that air can flow through the channel. This type of shield construction provides a 67% reduction of clearance.

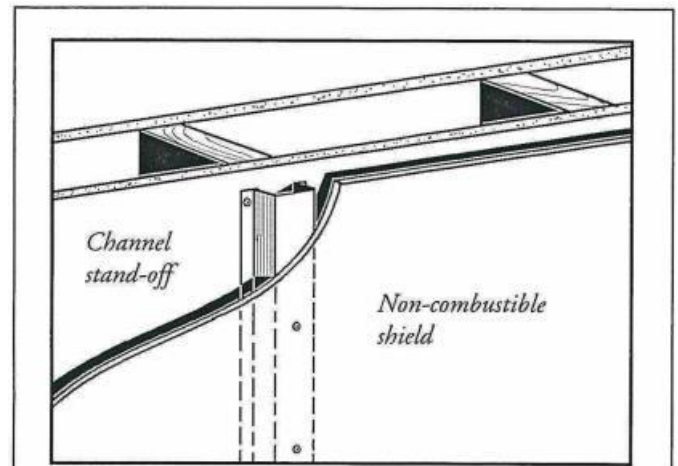

## CHANNEL STAND-OFF

Channel stand-offs provide better shield support and faster installation than tube spacers. Because the mounting screws do not pass from the face of the shield to the combustibles behind, channel stand-offs can be placed more directly behind the appliance.

Township of Guelph Eramosa

8348 Wellington Road 124 • Box 700 • Rockwood, ON • N0B 2K0

Phone: (519) 856-9596 • Fax: (519) 856-2240

## Chimneys

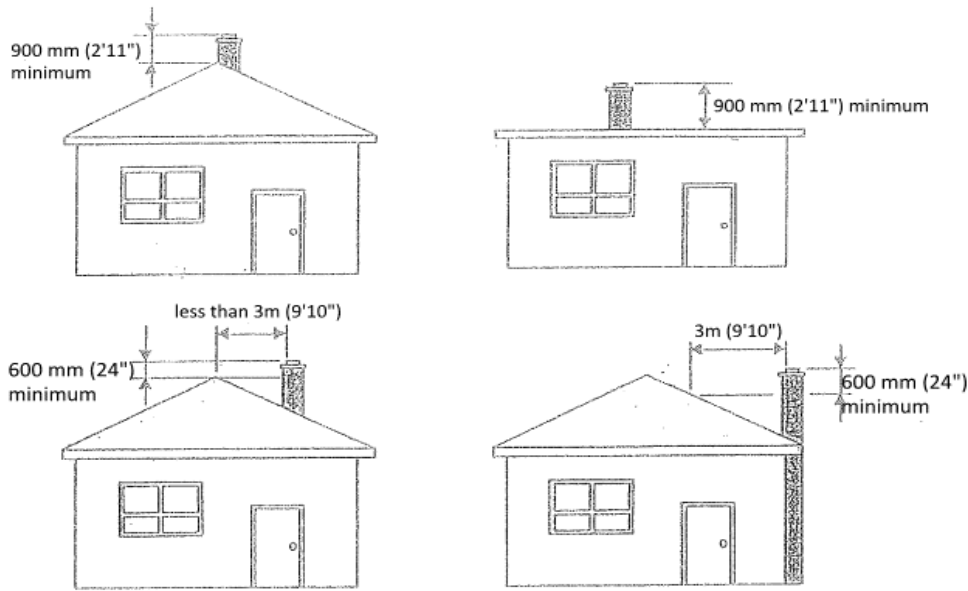

(9.21.4.4)

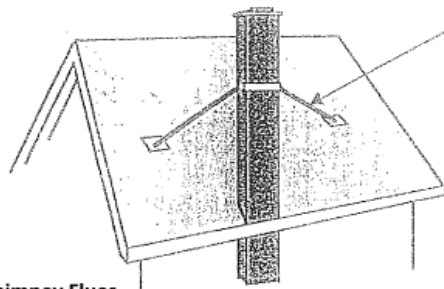

Bracing required when height of chimney is greater than 3.6 m (11'10") or as required to provide additional lateral stability

More than one tie is recommended (9.21.4.5)

Height of Chimney Flues

## Sample Floor Plan Showing Clearances to Combustible Construction

### Standard Installation

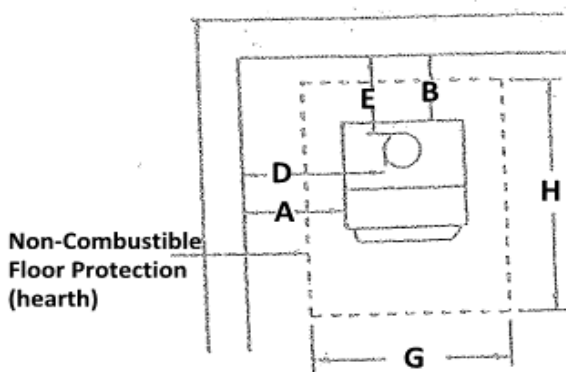

### Corner Installation

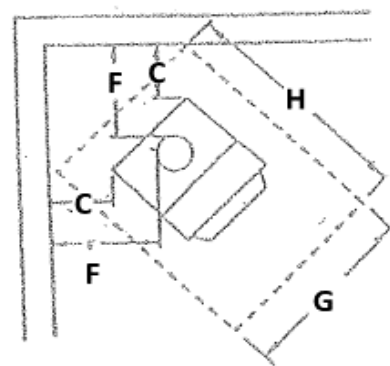

Clearance from Appliance to:

- A - Side wall
- B - Back wall
- C - Corner

Clearance from Smoke Pipe to

- D - Side wall
- E - Back wall
- F - Corner

G - Hearth Width

H - Hearth Length

Township of Guelph Eramosa

8348 Wellington Road 124 • Box 700 • Rockwood, ON • N0B 2K0

Phone: (519) 856-9596 • Fax: (519) 856-2240